

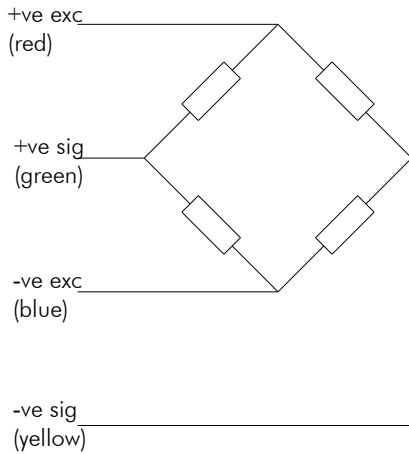

ET Series Underhook/Inline Load Link

- Range 1 to 500 tonne
- For use with standard shackle
- Sealed to IP66
- Integral electrical connector
- Robust Construction
- Low Weight



Options :
 Other ranges available on request
 Rechargeable battery powered handheld indicator, connected by cable.
 Carry case for transportation and storage of link and handheld

Capacities	1, 2, 5, 12, 25, 35, 50, 100, 250, 500	tonne
Full Load Output	1.5 (±0.25%)	mV/V
Zero Load Output	<±2.0	%
Excitation (Max)	10 (15)	V
Accuracy	<0.1	%
Repeatability	<0.05	%
Input Resistance	745 (±30)	Ω
Output Resistance	700 (±2)	Ω
Compensated Temp. Range	-10 to +40	°C
Operating Temp. Range	-20 to +60	°C
Temp. Coefficient on Zero	<0.0010	% Capacity/°C
Temp Coefficient on Span	<0.0010	% Capacity/°C
Safe Overload	150	%
Insulation	>500 @100Vdc	MΩ
Environmental Protection	IP66	
Cable Length	15	m

Specifications subject to change without notice

Type	A	B	C	D	E	WEIGHT (kg)
1, 2, 5 te	108	105	41.5	30	164	1.4
12 te	120	105	41.5	38	210	1.9
25 te	131	125	58	53	255	4
35 te	147	135	58	60	305	5
50 te	170	150	76	73	345	9
100 te	228	220	120	100	455	27
250 te	330	304	189	145	680	87
500 te	451	500	200	200	1015	225

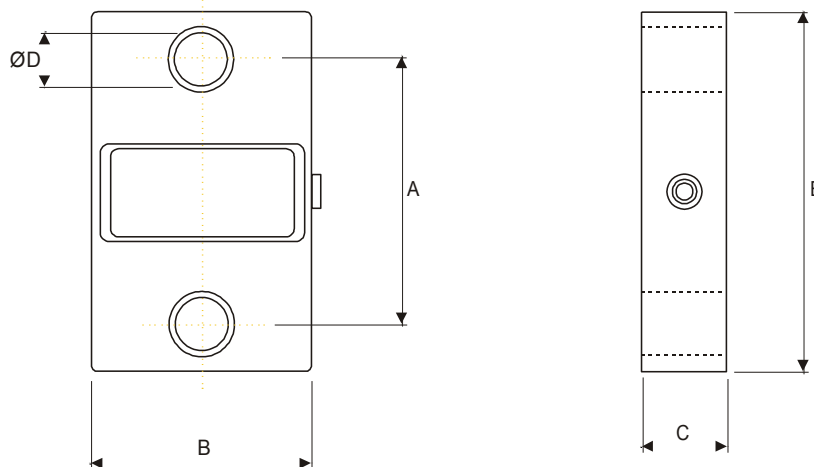

All dimensions in mm

Elite Transducers Ltd

5&6 Zephyr House, Calleva Park, Aldermaston, Reading, RG7 8JN

Tel: (+44) 0118 9811750 Fax: (+44) 0118 9811751

E-mail: info@elitetransducers.co.uk