

Compression Cell

25t to 1,000t

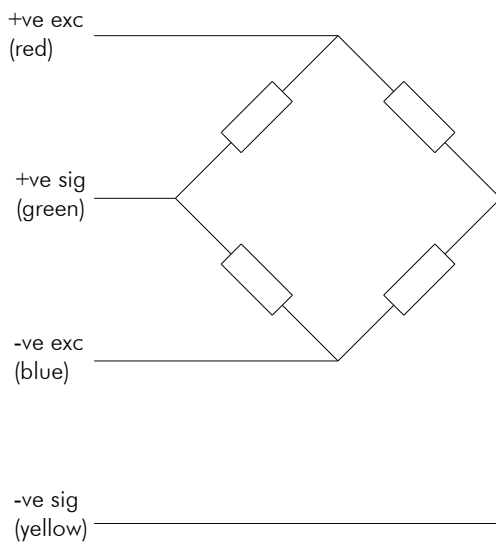

- Stainless Steel
- Sealed to IP67
- Spherical top
- O-Ring sealed
- Compression load cell
- 2 Year warranty
- Tilt plate option
- Tapped holes in base



Capacities	25, 50, 100, 150, 200, 300, 500, 800, 1000	tonne
Rated Output	2.0 nom.	mV/V
Accuracy	0.25	%
Repeatability	0.1	%
Input Resistance	375 or 750	Ω
Output Resistance	350 or 700	Ω
Compensated Temp. Range	-10 to +40	°C
Operating Temp. Range	-20 to +60	°C
Temp. Coefficient on Zero	<0.005	% Capacity/°C
Temp Coefficient on Span	<0.005	% Capacity/°C
Safe Overload	150	%
Insulation	>500 @100Vdc	MΩ
Environmental Protection	IP67	
Zero Balance	+/- 2	%RL
Cable Length	10	m

Specifications subject to change without notice

Capacity (t)	A	ØB	ØC	D	E	F	G
25, 50	155	72	60	101	30	82	M8 35PCD
100, 150, 200	170	108	88	145	40	82	M10 55PCD
300	223	135	107	175	50	109	M10 75PCD
500	295	165	138	225	75	114	M12 90PCD
800	362	203	176	270	95	137	M16 125PCD
1000	430	225	195	300	115	155	M20 125PCD

All dimensions in mm

Options :

- Amplifier 3-wire or 2-wire current loop
- Cable length
- Connector
- Sealed to IP68
- Fully potted
- Second redundancy bridge
- Atex approval
- Witness by Lloyds Reg., ABS etc.
- Tilt Plate

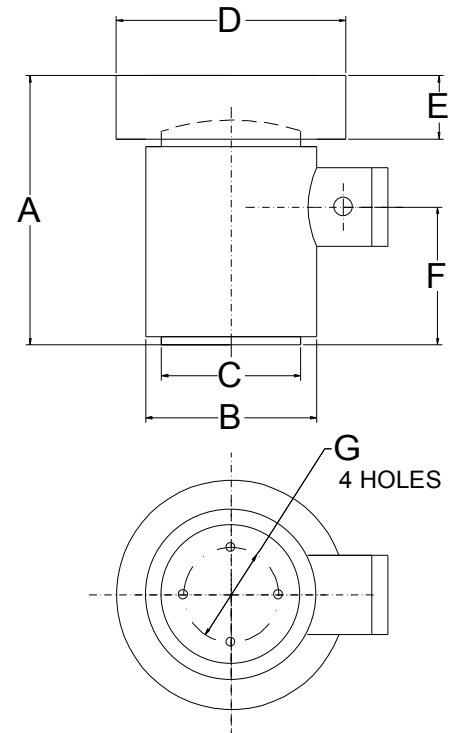

Elite Transducers Ltd

5&6 Zephyr House, Calleva Park, Aldermaston, Reading, RG7 8JN

Tel: (+44) 0118 9811750 Fax: (+44) 0118 9811751

E-mail: info@elitetransducers.co.uk

CLC
ATEX / IECEx Approved to
Ex ia IIC T6
Ex tb IIIC Db T85°C
(-40°C ≤ T_a ≤ +60°C)

